

SOD123-FL



The SOD123-FL package is part of the FLAT series of compact surface mount packages which allow communication equipment to be miniaturized. The Cu clip structure of interconnect features reduces electrical resistance and enhances thermal performance compared to wire-bonded products.

This package may also be know as:

- ▶ S-FLAT
- ▶ SMF
- ▶ STmite Flat
- ▶ JEDEC: DO-219 AB

Features

- ▶ Cu connector structure to reduce inductance and resistance
- ▶ Enhanced thermal properties
- ▶ Turnkey with test and packing services
- ▶ Green materials: Pb-free plating & halogen-free mold compound

New Developments

- ▶ Larger/higher density leadframe strips
- ▶ Environmentally friendly Pb-free solder paste

Process Highlights

- ▶ Bare copper leadframe with no plating
- ▶ Interconnect: Cu clips technology for better electrical and thermal performance
- ▶ Plating: 100% matte Sn
- ▶ Marking: Pen type laser

Applications

The FLAT package series is suitable for small and medium size high-efficiency diode applications:

- ▶ Schottky Barrier Diodes (SBDs)
- ▶ Rectifier Diodes
- ▶ Zener Diodes

Reliability Qualification

Amkor devices are assembled with proven reliable semiconductor materials.

- ▶ All test includes pre-condition of: Ta = 85°C/RH = 85%, 24 hrs with IR reflow, Ta = 260°C, 4X
- ▶ Temperature & Humidity Storage, Ta = 85°C/RH = 85%, 2000 hrs
- ▶ High Temperature Storage, Ta = 150°C, 2000 hrs
- ▶ Pressure Cooker, Ta = 121°C/RH = 100%/P = 2 atm, 500 hrs
- ▶ Temperature Cycle, -45~150°C, 1000 cycles

Test Service

Amkor offers full turnkey business for all power discrete products with the capability to test various types of power devices including MOSFETs, bipolar transistors, IGBTs, diodes and regulator ICs/intelligent power devices.

- ▶ Amkor power discrete test capability:
 - ▷ Static test (DC)
 - ▷ Dynamic test (AC, Switching/Trr, Capacitance/Rg)
 - ▷ Destruction test (Inductive load/VISUS, I Latch, Surge, Isolation/VIL)
 - ▷ Thermal Resistance (ΔV_{DS} , ΔmV , etc.)
- ▶ Program generation/conversion
- ▶ Failure analysis
- ▶ Available test/handling technology
- ▶ Integrated marking, vision inspection and tape & reel services

SOD123-FL

Standard Materials

- ▶ Leadframe: Bare copper
- ▶ Die attach: Solder paste
- ▶ Interconnect: Cu clips
- ▶ Mold compound: Halogen free

Shipping

- ▶ Tape and reel packing
 - ▷ 3000 pcs per reel
 - ▷ Tape width 8 mm
 - ▷ Reel Φ = 180 mm
- ▶ Barcode packing label
- ▶ Drop ship

Package Outline Drawing

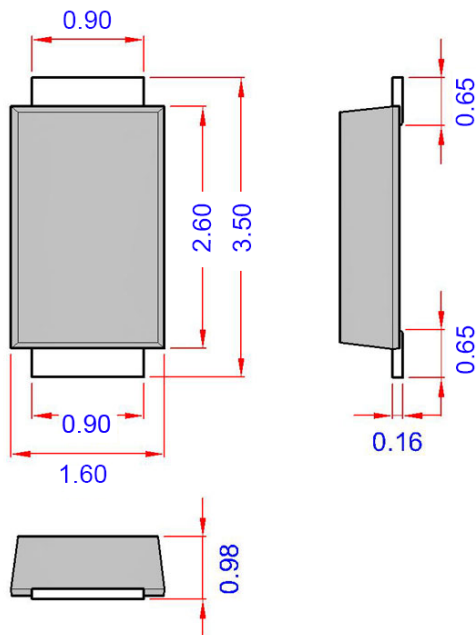

Cross-section

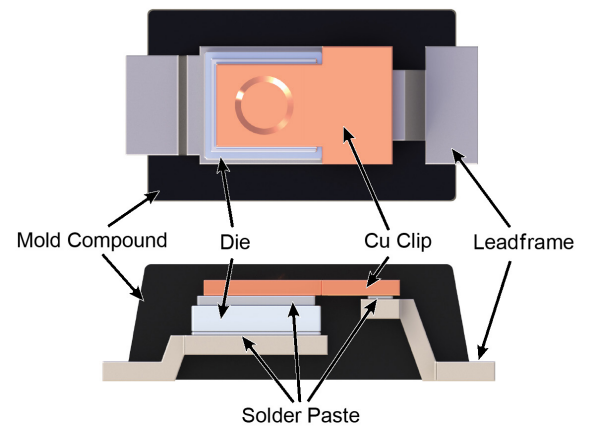

Visit amkor.com or email sales@amkor.com for more information.



With respect to the information in this document, Amkor makes no guarantee or warranty of its accuracy or that the use of such information will not infringe upon the intellectual rights of third parties. Amkor shall not be responsible for any loss or damage of whatever nature resulting from the use of, or reliance upon it and no patent or other license is implied hereby. This document does not in any way extend or modify Amkor's warranty on any product beyond that set forth in its standard terms and conditions of sale. Amkor reserves the right to make changes in its product and specifications at any time and without notice. The Amkor name and logo are registered trademarks of Amkor Technology, Inc. All other trademarks mentioned are property of their respective companies. © 2018, Amkor Technology Incorporated. All Rights Reserved. DS614C Rev Date: 10/18